

1010

ADVANCED GUITAR EFFECTS PROCESSOR

ZOOM PLAYER

Operation Manual

Thank you for selecting the *Advanced Guitar Effects Processor ZOOM Player 1010* (hereafter called "*1010*").

■ Outstanding Features

- **25 versatile built-in individual effects.**
Up to six effects can be combined in a patch, and up to 42 patches (12 user memory patches and 30 preset patches) are available, offering extraordinary flexibility.
- **Integrated auto-chromatic guitar tuner.**
- **Integrated foot switches and informative control panel show settings at a glance and allow easy operation like a compact effect.**
- **Distortion effect is generated using analog circuitry, to assure rich and natural-sounding sustain and distortion effect.**
- **By using the optional foot controller FP01, pedal wah and volume control are possible, for further enhanced playability.**

■ Contents

Panel Description	1
Top Panel	1
Rear Panel	2
Connections	2
Getting Familiar With Some Basic Terms	3
Using the Patches (Play Mode)	4
Panel Display in Play Mode	4
Selecting a Patch	4
Adjusting the Patch Level	5
Bypassing the Effects	5
Muting the Output	5
Tuning the Guitar	5
Guitar Tuner Calibration	6
Using a Foot Pedal	6
Creating a Patch (Edit Mode)	7
Activating Edit Mode	7
Editing a Patch	8
Switching Effect Modules On and Off	8
Storing a Patch	8
Effect Types and Parameters	9
Effect Module 1 (COMP & WAH)	9
Effect Module 2 (DISTORTION)	9
Effect Module 3 (EQ)	11
Effect Module 4 (CHO/FLG)	11
Effect Module 5 (REV/DLY)	12
Patch Level	12
Patch List	13
Reinitializing the 1010 (Special Mode)	13
Specifications	14

Panel Description

Top Panel

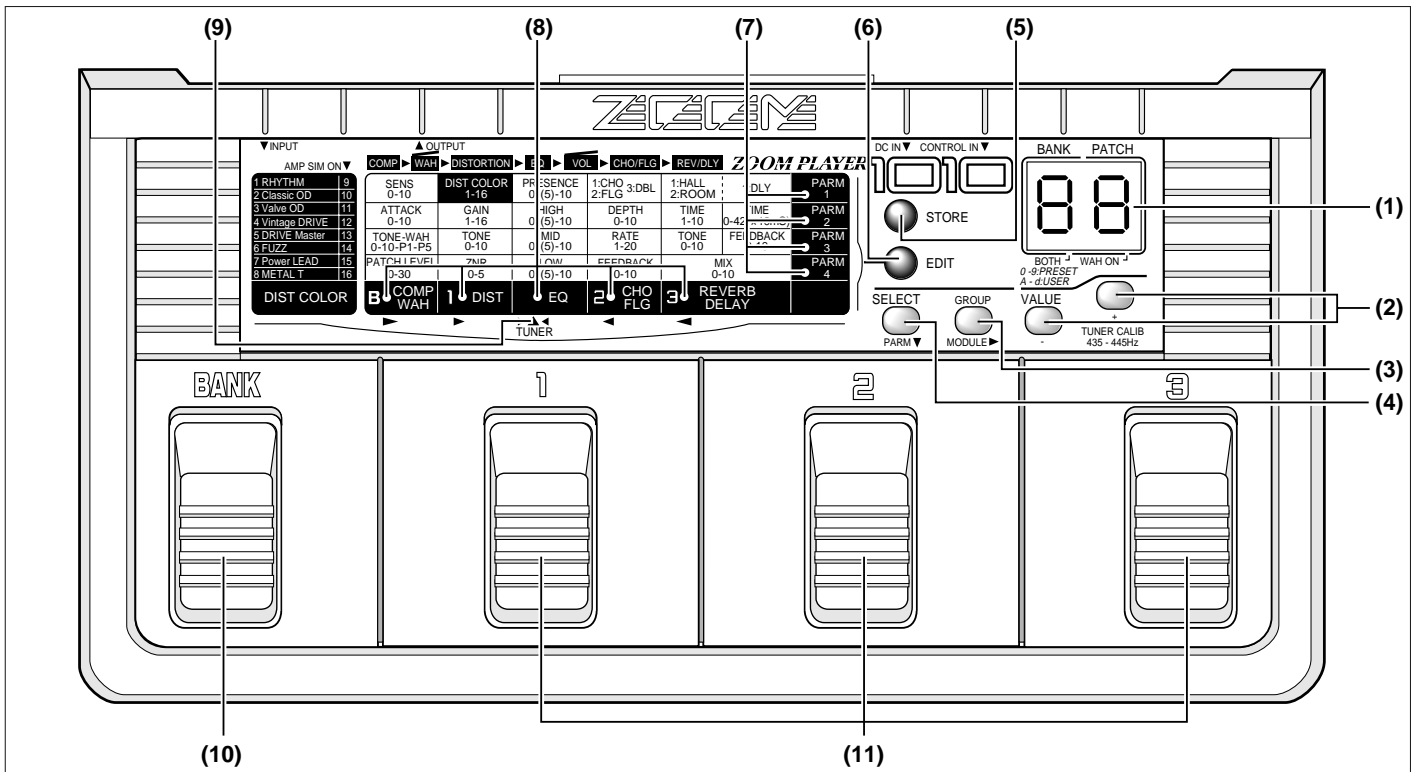

(1) Display

The display shows vital information for operating the 1010.

(2) VALUE + / - keys

These keys serve to change the value of a setting.

(3) MODULE SELECT ► key

● In Play mode

Serves to select the group (USER, PRESET or BOTH)

● In Edit mode

Serves to select the module to be edited.

(4) PARM/SELECT ▼ key

Serves to select the parameter to be edited.

(5) STORE key

Serves to store a patch.

(6) EDIT key

Serves to switch between Play mode and Edit mode.

(7) Parameter cursor indicators

In Edit mode, the flashing indicator indicates the edited parameter.

(8) Module cursor indicators

● In Play mode

Lit indicator indicates which effect module is ON.

● In Edit mode

Lit indicator indicates which effect module is ON, and flashing indicator indicates the currently edited effect module.

● In bypass/tuner mode

Indicators serve as tuning meter.

(9) Tuner indicator

Lights up in the bypass/tuner mode.

(10) BANK pedal

● In Play mode

Selects the next higher bank.

● In Edit mode

Switches the effect module COMP&WAH on and off.

(11) Pedals 1 – 3

● In Play mode

The pedals serve to select a patch.

● In Edit mode

The pedals serve to switch the effect modules DISTORTION, CHO/FLG, and REV/DLY on and off.

Rear Panel

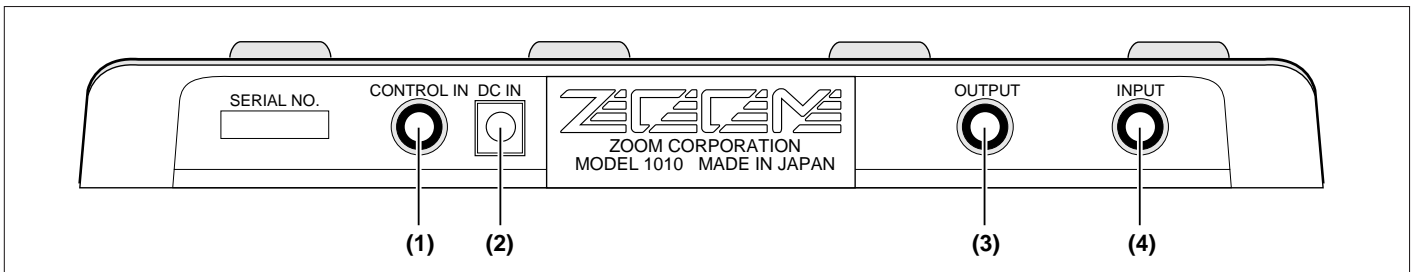

(1) CONTROL IN jack

This connector allows use of the optional foot pedal FP01 to control pedal wah or volume level.

(2) DC INPUT (AC adapter) jack

The supplied AC adapter is connected here. As long as the AC adapter is connected, the unit is turned on. There is no separate power switch.

(3) OUTPUT jack

Connects to the amplifier.

(4) INPUT jack

Connects to the guitar.

Connections

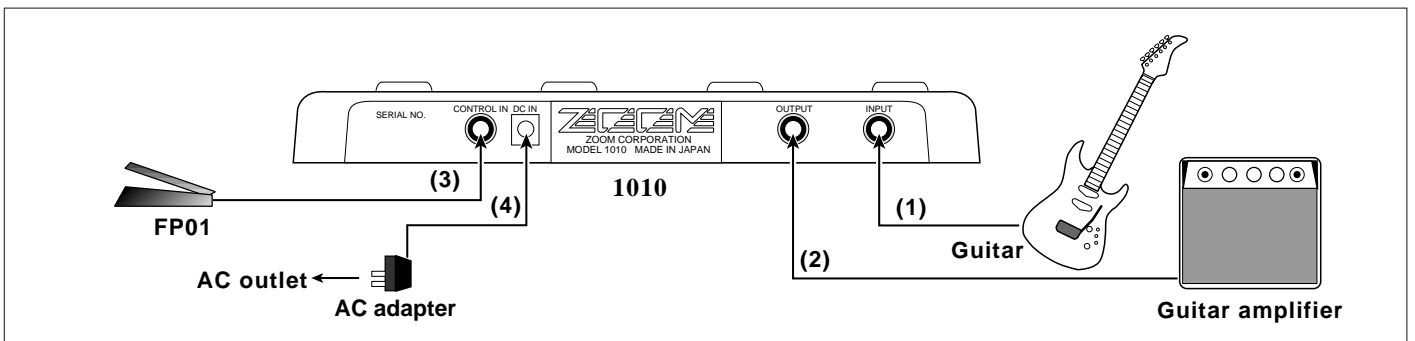

(1) Connect an electric guitar to the INPUT jack.

(2) Connect a guitar amplifier to the OUTPUT jack.

HINT When monitoring the sound through an audio speaker, distortion effects may sound too weak. If this happens, choose a distortion color with amplifier simulation.

For details regarding distortion color, please refer to the table of effect types on page 9.

(3) To control volume or wah with the foot pedal FP01, connect the pedal to the CONTROL IN jack of the 1010.

For details regarding use of the foot pedal, please refer to page 6.

(4) After all other connections are completed, plug in the supplied AC adapter.

This activates the unit.

NOTE Make sure that power to connected equipment is turned off before plugging in or unplugging the AC adapter of the 1010.

Getting Familiar With Some Basic Terms

■ Effect Module

The 1010 incorporates five effect blocks which are referred to as "effect modules". Each effect module can be thought of as a single compact effect. The 1010 therefore operates like five compact effects connected in series.

The following five types of effect modules are available:

● COMP&WAH

Compression effect and pedal wah (with an external controller)

● DISTORTION

Analog distortion effects

● EQ

Equalizer for adjusting the tonal quality of the sound

● CHO/FLG

Chorus and modulation effects.

● REV/DLY

Reverb and delay effects for creating a spatial impression

■ Effect Type

Each effect module contains several effect variations which are called "effect types". An effect module can normally use only one effect type at a time, but the COMP&WAH module can use compressor and wah together. The DISTORTION module utilizes ZNR (Zoom Noise Reduction) in addition to distortion effect. For a list of effect types in each effect module, please see the table on page 9.

■ Patches and Groups

A combination of effect modules, each with individual parameter settings plus the final output level setting is referred to as a "patch".

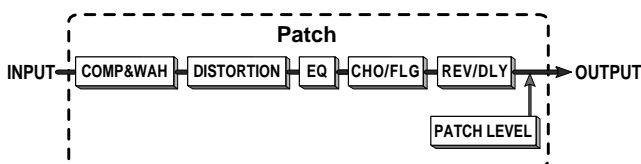

The 1010 has two memory areas or "groups" where patches are stored: the USER group for patches that can be altered and stored by the user, and the PRESET group for factory defined read-only patches. There are 12 patches in the USER group and 30 patches in the PRESET group, for a total of 42 patches.

■ Bank

The 1010 calls up patches in sets of three, and the foot pedals serve to switch between patches. Each set of three patches is referred to as a "bank".

Group	Bank	Patch number
USER	A	1-3
	b	1-3
	C	1-3
	d	1-3
PRESET	0	1-3
	1	1-3
	2	1-3
	3	1-3
	4	1-3
	5	1-3
	6	1-3
	7	1-3
	8	1-3
9	1-3	

■ Parameter

The elements which determine the sound of an effect are referred to as "parameters". Parameter values can be adjusted for each effect module, to create your own patches with the 1010.

■ Mode

The functions of the 1010 can be divided into three different categories. These are called "modes", as described below.

● Play Mode (Please refer to page 4)

In this mode, patches are selected and played. This is the default mode when power is turned on.

● Edit Mode (Please refer to page 7)

In this mode, the parameters of each patch can be edited.

● Special Mode (Please refer to page 13)

Serves to return some or all patch data to the factory preset settings.

Using the Patches (Play Mode)

1. First make sure that the AC adapter of the 1010 is disconnected and that the amplifier is switched off. Then connect the 1010 to the guitar and amplifier.
2. Plug in the AC adapter of the 1010 to activate the unit and switch the amplifier on.
3. Adjust the volume to a suitable position while playing the instrument.

Panel Display in Play Mode

When the 1010 is turned on by plugging in the AC adapter, the unit automatically goes into Play mode. In the Play mode, the following information is shown on the display.

(1) Bank

The currently selected bank is shown in the BANK field (left side) of the display.

- **USER** : A, b, C, d
- **PRESET** : 0, 1, 2, 3, 4, 5, 6, 7, 8, 9

(2) Patch number

The currently selected patch number is shown in the PATCH field (right side) of the display.

(3) WAH on/off

The wah on/off condition of the currently selected effect is shown by a dot in the lower right corner of the display. (Pedal wah is possible when the optional foot pedal FP01 is connected.)

(4) Effect module on/off

The effect module on/off condition in the patch is indicated by the module cursor indicator.

Selecting a Patch

1. Select the desired group with the PARAM SELECT ► key.

In the 1010, patches are divided into the USER group and the PRESET group. Choose the group from which you want to select a patch. With each push of the PARAM SELECT ► key, the group setting cycles through the following three settings which are shown on the display.

- **A (USER)** USER group only
- **0 (PRESET)** PRESET group only
- **A or 0 (BOTH)** USER group and PRESET group

2. Select the bank with the BANK pedal.

A bank is a group of three patches. There are four banks (named A through d) in the USER group and 10 banks (0–9) in the PRESET group. When wishing to continuously select patches from both groups, choose the BOTH setting. With each push of the BANK pedal, the next higher bank is selected. (The bank display flashes during bank selection.)

NOTE Merely pressing the BANK pedal does not yet change the patch. To activate the patch and change the sound, press one of the pedals 1–3, as described below.

3. Select the patch by pressing one of the pedals 1–3.

The patch number is shown on the right side of the display. (The bank indication is now constantly lit.)

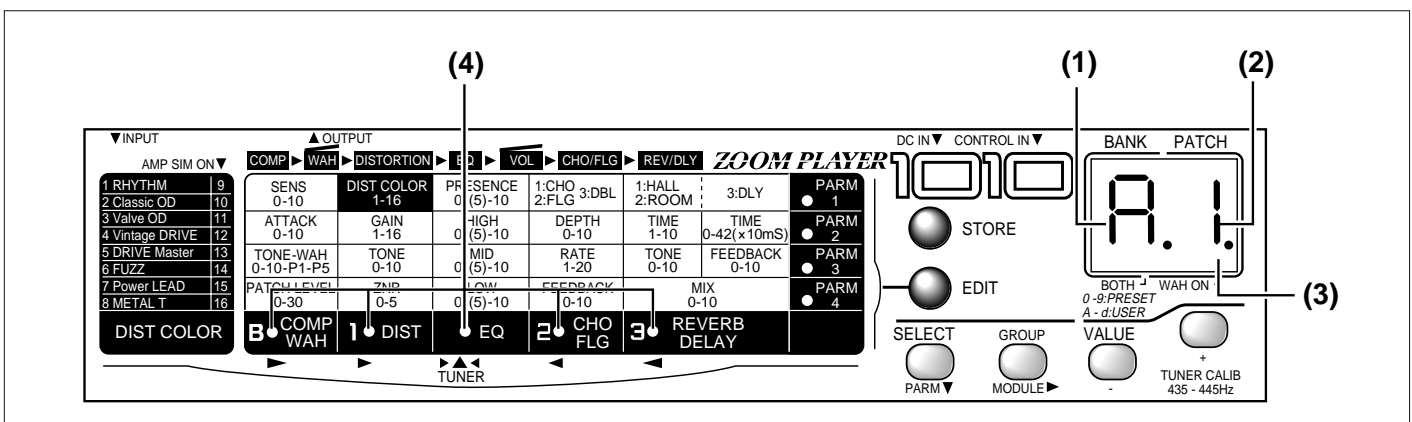

Adjusting the Patch Level

The output level of the patch is called the patch level. In the Play mode, the patch level can be adjusted.

1. Press the VALUE + / - keys in the Play mode.

When one of the VALUE + / - keys is pressed, the current patch level setting is shown on the display as a numeric value (0 – 30). In this condition, the PARAM4 indicator and COMP&WAH indicator are flashing. Pressing VALUE + increases the value and pressing VALUE - decreases it. To change values continuously, hold down the key.

 *The patch level setting change made in this way is only temporary. If you select a different patch without storing the new level setting first, the setting will be lost. In the Play mode, the patch level can be adjusted also for patches from the PRESET group, but the new level setting cannot be stored. When wishing to store the level, store the patch in the USER group.*

For details on how to store settings, please refer to page 8.

Bypassing the Effects

You can temporarily turn off all effects in a patch. This is useful for example to compare the original sound with the sound of a patch.

1. In the Play mode, press the pedal 1 – 3 whose number is shown on the right side of the display (i.e. the pedal that was used to select the current patch).

 *For example, if the patch number shown on the right side of the display is "1", press pedal 1 to bypass the effects.*

2. All effects in the patch are now bypassed and the original guitar sound is heard.

The display shows "bP" for one second to indicate that bypass has been selected, and then switches to tuner indication (if no sound is input from the guitar, the display shows "--"). The tuner indicator also lights up.

 *The above explanation uses the expression "original sound" for the sound that is heard in the bypass condition. However, since the 1010 uses digital processing for the signal routed through it (both in the "effect ON" and effect OFF condition), the output will not be exactly the same as when directly plugging the guitar into the amplifier.*

3. To return to the Play mode, press one of the pedals 1 – 3 to select a patch.

 *To return to the previously selected patch, simply press the BANK pedal.*

Muting the Output

You can temporarily mute the entire output from the 1010, which is useful for example when wishing to tune an instrument on stage.

1. To mute the output in the Play mode, press the pedal 1– 3 whose number is shown on the right side of the display (i.e. the pedal that was used to select the current patch), and keep the pedal depressed for more than one second.

 *For example, if the patch number shown on the right side of the display is "1", keep pedal 1 depressed for at least one second to mute the output.*

2. The output of the 1010 is now completely cut off and the sound of the guitar cannot be heard.

When the pedal is depressed, the indication "bP" appears first on the display, but if the pedal is kept depressed for more than one second, the indication changes to "flE" to indicate that the output has been muted. The display shows the indication " E" for one second and then switches to tuner indication (if no sound is input from the guitar, the display shows "--"). The tuner indicator also lights up.

3. To return to the Play mode, press one of the pedals 1 – 3 to select a patch.

 *To return to the previously selected patch, simply press the BANK pedal.*

Tuning the Guitar













The 1010 incorporates an automatic guitar tuning function. When the 1010 is set to the bypass or mute mode, the tuning function is automatically enabled.

1. In the Play mode, press the pedal whose number is shown on the right side of the display (i.e. the pedal that was used to select the current patch), to activate the bypass or mute mode.

The tuner indicator lights up.

2. Pick an open string on the guitar.

The display shows the note which is closest to the current pitch. Tune the guitar to the desired pitch.

C = 	F = 	A = 
C# = 	F# = 	A# = 
D = 	G = 	B = 
D# = 	G# = 	
E = 		

3. When the display shows the desired note, perform fine

tuning.

While the tuner function is being used, the module cursor indicators serve as a fine tuning meter. When the pitch is correct, the EQ indicator lights. If the pitch is too high, the REV/DLY indicator lights, and if it is too low, the COMP&WAH indicator lights. Watch the indicators while fine tuning your instrument.

SENS 0-10	DIST COLOR 1-16	PRESENCE 0-(5)-10	1:CHO 3:DBL 2:FLG	1:HALL 2:ROOM	3:DLY
ATTACK 0-10	GAIN 1-16	HIGH 0-(5)-10	DEPTH 0-10	TIME 1-10	TIME 0-42(x10mS)
TONE-WAH 0-10-P1-P5	TONE 0-10	MID 0-(5)-10	RATE 1-20	TONE 0-10	FEEDBACK 0-10
PATCH LEVEL 0-30	ZNR 0-5	LOW 0-(5)-10	FEEDBACK 0-10	MIX 0-10	
B COMP WAH	1 DIST	• EQ	2 CHO FLG	3 REVERB DELAY	

TUNER

4. To return to the Play mode, press one of the pedals 1 - 3 to select a patch.



To return to the previously selected patch, simply press the BANK pedal.

Guitar Tuner Calibration

The reference frequency of the integrated guitar tuner can be adjusted for the reference note A.

- In the Play mode, press the pedal whose number is shown on the right side of the display (i.e. the pedal that was used to select the current patch), to activate the bypass or mute mode. The tuner indicator lights up.
- Press one of the VALUE + / - keys.
- The current reference frequency is shown for a brief duration on the display.
- While the reference frequency is shown, use the VALUE + / - keys to adjust the frequency.

The adjustment range is 435 to 445 Hz. This is shown on the display as "35" - "45".



The default reference frequency setting that is established when the 1010 is turned on is 440 Hz.

435Hz : 35
440Hz : 40
445Hz : 45

Using a Foot Pedal

Controlling the volume

- Connect the FP01 to the CONTROL IN jack of the 1010.
- Operate the FP01 while using the 1010 in Play mode.



The volume adjustment made with the foot pedal is independent from the patch level setting of the individual patches. The control tap is located between the EQ and the CHO/FLG module. This allows changing the volume without reducing reverb or delay intensity.



If wah control is selected in the COMP&WAH module, this will be activated automatically, and volume control is disabled.

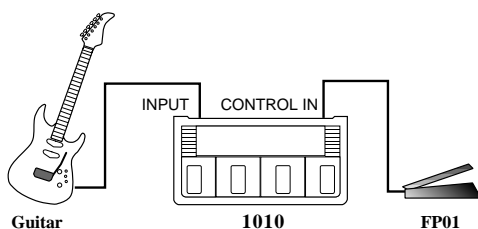

Using the wah effect of the 1010 as pedal wah

- Connect the FP01 to the CONTROL IN jack of the 1010.
- Select a patch from the COMP&WAH module which uses pedal wah.
For details on how to select a patch, please refer to page 4.
- Operate the FP01 while using the 1010 in Play mode. The pedal now controls pedal wah.



To be able to use wah, set the COMP&WAH module to ON in Edit mode and set PARAM3 to any setting between P1 and P5. (For details, please refer to the Edit mode explanation starting on page 7 and the explanation of effect types and parameters starting on page 9.)



If wah is enabled in the patch, a dot appears in the lower right corner of the display.

Use the EXP. OUT jack of the FP01 for connection to the CONTROL IN jack of the 1010.

Use the stereo cable supplied with the FP01 for making the connection.

Creating a Patch (Edit Mode)

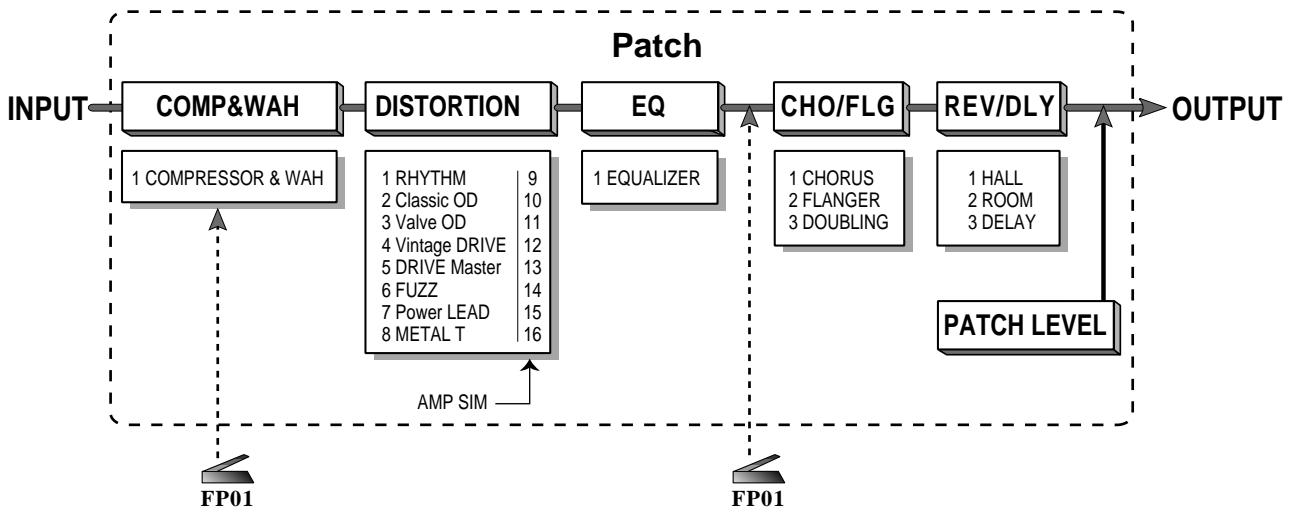

As shown in the illustration above, a patch of the 1010 contains parameters for the five types of effect modules and the patch level settings. In the Edit mode, you can call up any of these parameters and change them.

Activating Edit Mode

1. Select the desired patch in the Play mode (from the USER group or the PRESET group).

NOTE For details on how to select a patch, please refer to page 4.

2. Press the EDIT key.

The 1010 is now in the Edit mode. The flashing module indicator shows which effect module is selected for editing, and the flashing parameter indicator shows which parameter within the module is selected for editing.

3. Pressing the EDIT key once more returns the 1010 to the Play mode.

Panel display in Edit mode

In the Edit mode, the following information is shown.

(1) Effect module on/off

The module cursor indicators of effect modules which are ON in the selected patch are lit.

(2) Parameter type

The type of the parameter currently selected for editing is indicated by the cross point of the flashing module cursor indicator and parameter cursor indicator.

(3) Parameter value

The value of the parameter currently selected for editing is shown on the display.

Editing a Patch

1. Press the EDIT key to activate the Edit mode.

2. Use the MODULE SELECT ► key to select the effect module you wish to edit.

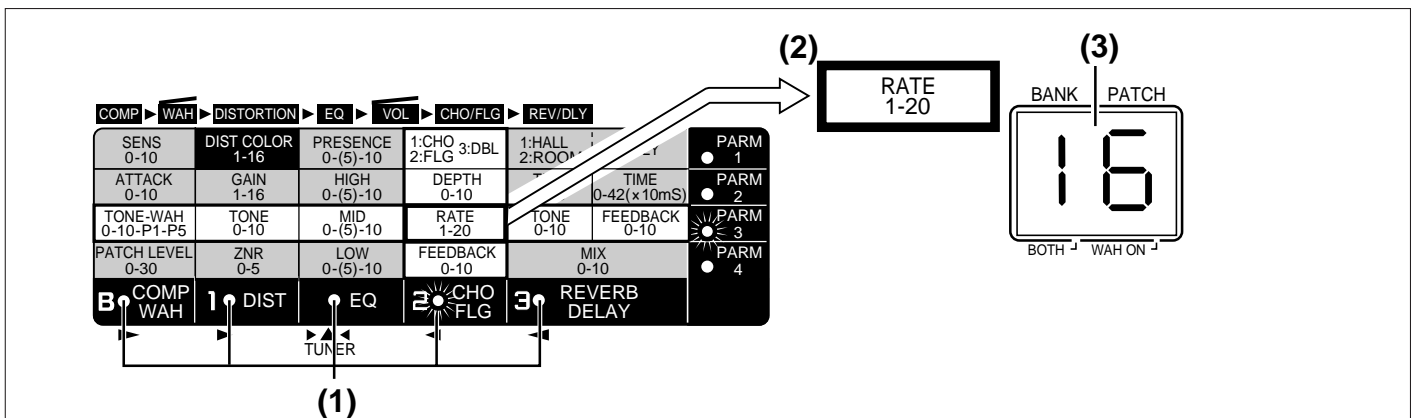

The indicator of the effect module currently selected for editing is flashing.

NOTE With each push of the **MODULE SELECT** key, the edited module moves one position to the right. When the **REV/DLY** module is reached, the cursor loops back to the **COMP&WAH** module.

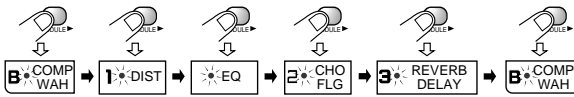

3. Next, use the **PARAM SELECT** key to select the parameter within that module that you wish to edit.

The indicator of the selected parameter is flashing.

NOTE With each push of the **PARAM SELECT** key, the selected parameter moves one position down. When **PARAM 4** is reached, the cursor loops back to **PARAM 1**.

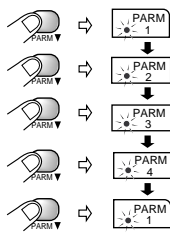

HINT The value of the selected effect parameter is shown on the display. If the display shows only "--", the effect module is OFF. Set the effect module to ON before editing, as described on page 8.

4. Use the **VALUE +/-** keys to change the parameter value.

HINT For details on the parameters of each effect module, please refer to "Effect Types and Parameters" on pages 9 – 12.

NOTE Parameter setting changes made in this way are only temporary. If you return to the Play mode or select a different patch without storing the new settings first, the settings will be lost.

For details on how to store a patch, please refer to the explanation at right.

Switching Effect Modules On and Off

In the Edit mode, effect modules can be turned on and off independently.

1. Pressing a pedal corresponding to an effect module that is currently on (module cursor indicator lit) turns the effect module off. The indicator goes out.

2. Press the pedal again to turn the effect module back on.

NOTE The **EQ** module cannot be switched off. To disable this module, set all parameters (**PARAM 1** through **PARAM 4**) to the value "5".

HINT The pedals 1 – 3 and the **BANK** pedal correspond to the following effect modules:

- **BANK** pedal: **COMP&WAH**
- **Pedal 1**: **DISTORTION**
- **Pedal 2**: **CHO/FLG**
- **Pedal 3**: **REV/DLY**

The effect module **ON/OFF** setting can also be stored as part of a patch.

Storing a Patch

If an edited patch is not stored, the change will be lost when another patch is selected. To preserve a setting, store the patch as described below.

1. Press the **STORE** key in the Edit mode.

This activates the store standby condition.

HINT Storing is possible also in the Play mode.

2. Choose the bank and patch number in which you want to store the patch.

Use the **BANK** pedal to first select the bank and then specify the patch number with the pedals 1 – 3.

NOTE Patches cannot be stored in the **PRESET** group. If a patch was chosen from the **PRESET** group, the store destination will automatically become the **USER** group. Specify a bank and patch number in the **USER** group.

3. If no bank and patch number is specified for a patch selected from the **USER** group, the patch will be stored in the original location.

If no bank and patch number is specified for a patch selected from the **PRESET** group, the patch will be stored in "A1" of the **USER** group.

HINT When a patch is stored, the patch that was previously stored in that number will be overwritten (erased). Take care not to erase a patch that you want to keep. When wishing to restore all factory preset patches, please refer to "Reinitializing the 1010 (Special Mode)" on page 13. Restoring individual patches is not possible.

4. Press the **STORE** key again. The patch is stored, and the 1010 reverts to the Play mode.

NOTE If the **STORE** key has not yet been pressed for the second time, you can use the **EDIT** key to cancel the store process and return to the Play mode.

Effect Types and Parameters

In this section, all effect types and parameters of the 1010 are explained.

Parameters that are the same for several effects are explained in detail only the first time they appear.

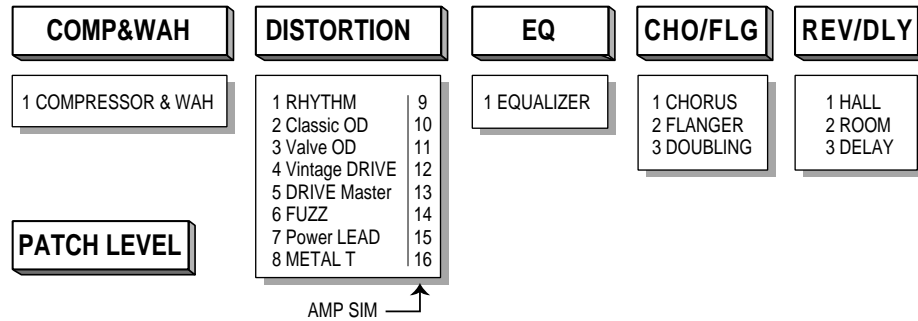

Effect Module 1 COMP & WAH (Compressor & Wah)

This module combines a compression with a wah effect. Using the compressor and wah together is also possible.

1 COMP & WAH (Compressor & Wah)

The compressor maintains the volume at a given level without impairing the sense of tone and attack. Wah emphasizes the frequency of the guitar. If the optional foot pedal FP01 is used, the emphasized frequency range can be shifted up and down with the pedal.

1 COMP & WAH

PARAMETER 1	SENS	0–10
PARAMETER 2	ATTACK	0–10
PARAMETER 3	TONE	0–10
	WAH	P1–P5

Description

(1) SENS (Sensitivity)

Determines the compressor depth. Higher values result in a more uniform level and longer sustain. A setting of "0" turns the compressor off. This is suitable for using only the wah effect.

(2) ATTACK

Determines the time lag between the guitar sound input and the onset of compression. Lower values produce faster attack.

(3) TONE

This is a tone-control-type equalizer. The neutral setting is 0 (zero). Low values emphasize the bass and high values emphasize the treble range.

(4) WAH

When the foot pedal FP01 is connected, set PARAM3 to any value from P1 to P5. These parameters control the emphasized frequency range when no pedal is connected. Higher values mean higher frequency.

Effect Module 2 DISTORTION

This module comprises eight kinds of distortion effects and eight different amp simulators (which recreate the sound of picking up a guitar amplifier with a microphone).

HINT When using the unit with a guitar amplifier, choose settings 1–8. When monitoring via an audio speaker or headphones, use settings 9–16.

NOTE This module also comprises ZNR (Zoom Noise Reduction). Adjust it to match the connected guitar.

1 9 RHYTHM

This effect gives a dry, cool sound with subdued bass and accentuated highs. It is well suited for blues or rhythm backing.

1 9 RHYTHM

PARAMETER 1	COLOR	1–16
PARAMETER 2	GAIN	1–16
PARAMETER 3	TONE	0–10
PARAMETER 4	ZNR	0–5

Description

(1) COLOR

Determines the distortion color. For normal rhythm play, use "1" and for rhythm play with amp simulator effect, use "9".

(2) GAIN

Determines distortion intensity of the overdrive circuit. Higher values produce more distortion.

(3) TONE

This is a tone-control-type equalizer.

(4) ZNR (Zoom Noise Reduction)

Control the ZNR circuit which reduces unwanted noise. Adjusting the value controls the amount of Zoom Noise Reduction.

2 10 Classic OD (Classic Overdrive)

This gives natural sounding overdrive distortion similar to that achieved with conventional compact effects.

2 10 Classic OD

PARAMETER 1	COLOR	1–16
PARAMETER 2	GAIN	1–16
PARAMETER 3	TONE	0–10
PARAMETER 4	ZNR	0–5

Description

(1) COLOR

To select normal classic overdrive, set this parameter to "2". To add the amp simulator effect, use "10".

(2) GAIN

Determines distortion intensity of the overdrive circuit. Higher values produce more distortion.

3 11 Valve OD (Valve Overdrive)

This gives warm sounding distortion similar to that of a tube amplifier.

3 11 Valve OD

PARAMETER 1	COLOR	1–16
PARAMETER 2	GAIN	1–16
PARAMETER 3	TONE	0–10
PARAMETER 4	ZNR	0–5

Description

(1) COLOR

To select normal valve overdrive, set this parameter to "3". To add the amp simulator effect, use "11".

4 12 Vintage DRIVE

This gives distortion with a bass boost and solid character.

4 12 Vintage DRIVE

PARAMETER 1	COLOR	1–16
PARAMETER 2	GAIN	1–16
PARAMETER 3	TONE	0–10
PARAMETER 4	ZNR	0–5

Description

(1) COLOR

To select normal vintage overdrive, set this parameter to "4". To add the amp simulator effect, use "12".

(2) GAIN

Determines distortion intensity of the overdrive circuit. Higher values produce more distortion.

5 13 DRIVE Master

This gives hard distortion sound similar to driving a large amp to full level.

5 13 DRIVE Master

PARAMETER 1	COLOR	1–16
PARAMETER 2	GAIN	1–16
PARAMETER 3	TONE	0–10
PARAMETER 4	ZNR	0–5

Description

(1) COLOR

To select normal drive distortion, set this parameter to "5". To add the amp simulator effect, use "13".

6 14 FUZZ

This gives a vintage type fuzz sound. The TONE parameter can be used to vary the character.

6 14 FUZZ

PARAMETER 1	COLOR	1–16
PARAMETER 2	GAIN	1–16
PARAMETER 3	TONE	0–10
PARAMETER 4	ZNR	0–5

Description

(1) COLOR

To select normal fuzz distortion, set this parameter to "6". To add the amp simulator effect, use "14".

(3) TONE

Higher values give a treble-rich sound character with distortion mainly in the upper frequencies. Lower values yield a mild sound character.

7 15 Power LEAD

This gives hard distortion sound with an edge.

7 15 Power LEAD

PARAMETER 1	COLOR	1–16
PARAMETER 2	GAIN	1–16
PARAMETER 3	TONE	0–10
PARAMETER 4	ZNR	0–5

Description

(1) COLOR

To select normal power lead distortion, set this parameter to "7". To add the amp simulator effect, use "15".

(3) TONE

This is a tone-control-type equalizer.

8 16 METAL T

This gives distortion which stresses the upper and lower ends of the frequency spectrum, suitable for heavy metal.

8 16 METAL T

PARAMETER 1	COLOR	1-16
PARAMETER 2	GAIN	1-16
PARAMETER 3	TONE	0-10
PARAMETER 4	ZNR	0-5

Description

(1) COLOR

To select normal metal T distortion, set this parameter to "8". To add the amp simulator effect, use "16".

Effect Module 3 EQ

This equalizer module allows tone control in four bands. The module is always on. For flat response, set all parameters to "5".

1 EQUALIZER

This equalizer allows boost or cut in the presence (super-high), high, mid, and low frequency ranges.

1 EQUALIZER

PARAMETER 1	PRESENCE	0-(5)-10
PARAMETER 2	HIGH	0-(5)-10
PARAMETER 3	MID	0-(5)-10
PARAMETER 4	LOW	0-(5)-10

Description

(1) PRESENCE

Adjusts the range of harmonics and overtones of a guitar. "5" is flat, lower values produce a cut and higher values a boost.

(2) HIGH

Adjusts the treble range. "5" is flat, lower values produce a cut and higher values a boost.

(3) MID

Adjusts the midrange. "5" is flat, lower values produce a cut and higher values a boost.

(4) LOW

Adjusts the bass range. "5" is flat, lower values produce a cut and higher values a boost.

Effect Module 4 CHO/FLG (Chorus/Flanger)

This effect module comprises three effect types for modulation.

1 CHORUS

An effect sound with periodically changing pitch is added to the direct sound, for rich ambience.

1 CHORUS

PARAMETER 1	(EFFECT TYPE)	1-3
PARAMETER 2	DEPTH	0-10
PARAMETER 3	RATE	1-20
PARAMETER 4	FEEDBACK	0-10

Description

(1) EFFECT TYPE

Selects the effect type. To use the chorus effect, set the parameter to "1".

(2) DEPTH

Determines the modulation depth.

(3) RATE

Determines the modulation rate.

(4) FEEDBACK

Determines the signal level fed to the mixer circuit between the output of the EQ module and the input of the REV/DLY module.

2 FLANGER

An effect sound delayed by several dozen milliseconds is added to the direct sound, and the delay is periodically changed, resulting in a strong flanger effect.

2 FLANGER

PARAMETER 1	(EFFECT TYPE)	1-3
PARAMETER 2	DEPTH	0-10
PARAMETER 3	RATE	1-20
PARAMETER 4	FEEDBACK	0-10

Description

(1) EFFECT TYPE

To use the flanger effect, set the parameter to "2".

(4) FEEDBACK

Determines the amount of feedback, i.e. the proportion of the signal routed back to the input of the effect circuit. Increasing this parameter will result in a flanger with very pronounced character.

3 DOUBLING

An effect sound with short delay is added to the direct sound, giving the impression of multiple performers playing together.

3 DOUBLING

PARAMETER 1	(EFFECT TYPE)	1-3
PARAMETER 2	DEPTH	0-10
PARAMETER 3	RATE	1-20
PARAMETER 4	FEEDBACK	0-10

Description

(1) EFFECT TYPE

Selects the effect type. To use the doubling effect, set the parameter to "3".

(2) DEPTH

Determines the short delay duration. The value shown on the display multiplied by 10 is the delay in milliseconds. The range is 0 to 100 ms.

(3) RATE

Determines the ratio of direct sound and delayed sound. Higher values produce more delay.

(4) FEEDBACK

Determines the amount of feedback, i.e. the proportion of the signal routed back to the input of the effect circuit.

Effect Module 5 REV/DLY (Reverb/Delay)

This effect module comprises three types of reverb effects.

1 HALL

This effect simulates a natural hall, expansive sound.

1 HALL

PARAMETER 1	(EFFECT TYPE)	1-3
PARAMETER 2	TIME	1-10
PARAMETER 3	TONE	0-10
PARAMETER 4	MIX	0-10

Description

(1) EFFECT TYPE

Selects the effect type. To use the hall effect, set the parameter to "1".

(2) TIME

Determines the reverb time. Higher values produce longer reverb times.

(3) TONE

Determines the reverb tone. Higher values produce brighter sound.

(4) MIX

Determines the balance between direct sound and effect sound. "0" means direct sound only, and "10" means maximum reverb.

2 ROOM

This effect simulates a room with short reverberation.

2 ROOM

PARAMETER 1	(EFFECT TYPE)	1-3
PARAMETER 2	TIME	1-10
PARAMETER 3	TONE	0-10
PARAMETER 4	MIX	0-10

Description

(1) EFFECT TYPE

To use the room effect, set the parameter to "2".

3 DELAY

This is a conventional digital delay effect with a delay time of up to 420 milliseconds.

3 DELAY

PARAMETER 1	(EFFECT TYPE)	1-3
PARAMETER 2	TIME(X10mS)	0-42
PARAMETER 3	FEEDBACK	0-10
PARAMETER 4	MIX	0-10

Description

(1) EFFECT TYPE

Selects the effect type. To use the delay effect, set the parameter to "3".

(2) TIME

Determines the delay intervals in 10-ms steps.

(3) FEEDBACK

Determines the amount of feedback, i.e. the proportion of the signal routed back to the input of the effect circuit.

(4) MIX

Determines the mixing ratio between direct sound and delay sound. Higher values produce more delay.

Patch Level

PARAM4 of the effect module COMP&WAH controls the level setting for each patch. Although it is not an effect, it is also stored as a parameter along with the other parameters of the patch.

Patch Level

PARAMETER 4	PATCH LEVEL	0-30
-------------	-------------	------

Description

(4) PATCH LEVEL

Determines the output level of the patch.



When the EQ effect module is set to flat response and all other effect modules are set to OFF, setting this parameter to "25" results in the same sound as when the unit is bypassed.



This parameter can be set regardless of the ON/OFF setting of the COMP&WAH module. This parameter is also the only one which can be changed in the Play mode, by using the VALUE keys.

Patch List

USER GROU

BANK	PATCH 1	PATCH 2	PATCH 3
A	Power LEAD Power LEAD EQ DBL DELAY	MELLOW BALLAD COMP EQ CHO DELAY	JET SCREAM COMP Vintage DRIVE EQ FLG HALL
b	Man on the Far Mountain METAL T EQ HALL	New York Night COMP Classic OD EQ CHO ROOM	Half WAH WAH DRIVE Master EQ DBL DELAY
c	Master's Sound DRIVE Master EQ DBL	American ROCK with DLY COMP RHYTHM EQ DELAY	SPACY Arpeggio EQ FLG DELAY
d	Classic FUZZ FUZZ EQ ROOM	THE CRUNCH COMP Valve OD EQ ROOM	WAH CLEAN COMP+WAH EQ CHO HALL

PRESET GROU

BANK	PATCH 1	PATCH 2	PATCH 3
0	Studio BALLAD DRIVE Master EQ DBL HALL	Studio LEAD COMP DRIVE Master EQ CHO DELAY	Studio FUNK COMP EQ ROOM
1	Traditional ROCK COMP Classic OD EQ DBL	Jazzy TONE EQ DBL	BLUES NOTE RTYTHM EQ
2	OCT-BUS COMP FUZZ EQ ROOM	Like a WOMAN Power LEAD EQ ROOM	Everything EQ CHO DELAY
3	CROSS OVER Power LEAD EQ CHO DELAY	Jaguar & REV EQ HALL	Grand Flange COMP EQ FLG DELAY
4	Doubling & DELAY 370 COMP Classic OD EQ DBL DELAY	Double Treble COMP EQ CHO HALL	Retro FUZZ EQ DBL HALL
5	Deep DELAY LEAD COMP Vintage DRIVE EQ DBL DELAY	Clean HALL COMP EQ FLG HALL	WAH DIST(Jimi TALK) WAH FUZZ EQ ROOM
6	[LINE] Power LEAD * Power LEAD EQ DBL DELAY	[LINE] MELLOW BALLAD COMP EQ CHO DELAY	[LINE] JET SCREAM COMP *Vintage DRIVE EQ FLG HALL
7	[LINE] Man on the Far Mountain * METAL T EQ HALL	[LINE] New York Night COMP * Classic OD EQ CHO ROOM	[LINE] Half WAH WAH * DRIVE Master EQ DBL DELAY
8	[LINE] Master's Sound * DRIVE Master EQ DBL	[LINE] American ROCK with DLY COMP *RHYTHM EQ DELAY	[LINE] SPACY Arpeggio EQ FLG DELAY
9	[LINE] Classic FUZZ * FUZZ EQ ROOM	[LINE] THE CRUNCH COMP *Valve OD EQ ROOM	[LINE] WAH CLEAN COMP+WAH EQ CHO HALL

** You should set the ZNR parameter in the DISTORTION module to a suitable value for the connected guitar.

Reinitializing the 1010 (Special Mode)

factory preset condition

This special function initializes the unit and returns all 12 patches in the USER group to the factory preset condition. Use this function with care, because all patches you have stored in the unit will be irretrievably lost.

1. To protect the speaker, turn the amplifier volume to minimum, and then turn off the 1010 by disconnecting the AC adapter.
2. Turn the 1010 back on by connecting the AC adapter while keeping the STORE key depressed.

The indication "AL" flashes on the display. This shows that the unit is ready for recalling all patches from the internal ROM.

3. When wishing to initialize all patches, press the STORE key once more. This restores all patches to their factory preset condition. The 1010 then switches to the Play mode.

● When wishing to cancel the function

Press the EDIT key. The 1010 switches to the Play mode without changing the patch settings.

Specifications

ZOOM PLAYER 1010

Effect types	25 (max. 6 simultaneous) Compressor, Wah, Distortion (8 types x 2), Equalizer, Chorus, Flanger, Doubling, Hall reverb, Room reverb, Mono delay
Effect modules	5 (max. 5 simultaneous)
Patches	USER 4 banks x 3 = 12 (user-writable) PRESET 10 banks x 3 = 30 Total 42
A/D conversion:	18-bit 128-times oversampling converter
D/A conversion:	18-bit 128-times oversampling converter
Sampling frequency	31.25 kHz
Inputs:	Guitar input Phone jack (Mono) x 1 (nominal input level -20 dBm, input impedance 470 k Ω)
Outputs:	Line Phone jack (Mono) x 1 (nominal output level +5 dBm, output impedance 1 k Ω or less)
Control connectors:	Foot pedal input for volume/wah control
Display:	2-character, 7-segment LED display
Power supply:	9 V DC, 300 mA (from supplied AC adapter)
Dimensions:	270 x 136.5 x 34 (W x D x H)
Weight:	1 kg

* 0 dB = 0.775 Vrms

* Design and specifications subject to change without notice.

■ Safety Precautions

Please observe the following safety tips and precautions to ensure hazard-free use of the 1010.

● Power requirements

The 1010 is powered by the supplied AC adapter . To prevent malfunction and safety hazards, Do not use any other kind of AC adapter.

When using the 1010 in an area with a different line voltage, please consult your local ZOOM distributor about acquiring a proper AC adapter.

● Environment

Avoid using your 1010 in environments where it will be exposed to:

- Extreme temperature
- High humidity or moisture
- Excessive dust or sand
- Excessive vibration or shock

● Handling

Since the 1010 is a precision electronic device, avoid applying excessive force to the switches and buttons. Also take care not to drop the unit, and do not subject it to shock or excessive pressure.

● Alterations

Never open the case of the 1010 or attempt to modify the product in any way since this can result in damage to the unit.

● Connecting cables to input and output jacks

You should always turn off the power to the 1010 and all other equipment before connecting or disconnecting any cables. Also make sure to disconnect all cables and the AC adapter before moving the 1010.

■ Usage Precautions

● Electrical interference

The 1010 uses digital circuitry that may cause interference and noise if placed too close to other electrical equipment, such as TV sets and radio receivers. If such problems occur, move the 1010 further away from the affected equipment. Also, when fluorescent lights or devices with built-in motors are close to the 1010, the unit may not function properly.

● Cleaning

Use a soft, dry cloth to clean the 1010. If necessary, slightly moisten the cloth. Do not use abrasive cleanser, wax, or solvents (such as paint thinner or cleaning alcohol), since these may dull the finish or damage the surface.

Please keep this manual in a convenient place for future reference.



ZOOM CORPORATION

NOAH Bldg., 2-10-2, Miyanishi-cho, Fuchu-shi, Tokyo 183, Japan
PHONE: 0423-69-7111 FAX: 0423-69-7115